

See discussions, stats, and author profiles for this publication at: <https://www.researchgate.net/publication/236593429>

# Influence of hydrodynamic conditions on the production and fate of *Posidonia oceanica* in a semi-enclosed shallow basin (Stagnone Di Marsala, Western Sicily)

Article in *Chemistry and Ecology* · June 2004

DOI: 10.1080/02757540410001689786

CITATIONS

30

READS

249

8 authors, including:



**Goffredo la Loggia**

Università degli Studi di Palermo

149 PUBLICATIONS 2,292 CITATIONS

[SEE PROFILE](#)



**Giuseppe Ciralo**

Università degli Studi di Palermo

135 PUBLICATIONS 2,066 CITATIONS

[SEE PROFILE](#)



**Maria Pirrotta**

Università degli Studi di Palermo

26 PUBLICATIONS 645 CITATIONS

[SEE PROFILE](#)



**Gianluca Sarà**

Università degli Studi di Palermo

230 PUBLICATIONS 5,346 CITATIONS

[SEE PROFILE](#)

Some of the authors of this publication are also working on these related projects:



CALYPSO HF Radar monitoring system and response against marine oil spill in the malta channel, PO Italia-Malta 2007-2013 [View project](#)



FLT Mediterranean Monitoring Network \_marine species and threats [View project](#)

# INFLUENCE OF HYDRODYNAMIC CONDITIONS ON THE PRODUCTION AND FATE OF POSIDONIA OCEANICA IN A SEMI-ENCLOSED SHALLOW BASIN (STAGNONE DI MARSALA, WESTERN SICILY)

G. LA LOGGIA<sup>a</sup>, S. CALVO<sup>b</sup>, G. CIRAOLO<sup>a</sup>, A. MAZZOLA<sup>c</sup>, M. PIRROTTA<sup>b</sup>,  
G. SARA<sup>c</sup>, A. TOMASELLO and S. VIZZINI

<sup>a</sup> Dipartimento di Ingegneria Idraulica ed Applicazioni Ambientali, Università di Palermo, viale delle Scienze 90100, Palermo, Italy; Dipartimento di Scienze Botaniche, Università di Palermo, via Archirafi 38, 90123, Palermo, Italy;

<sup>c</sup> Dipartimento di Biologia Animale, Università di Palermo, via Archirafi 18, 90123 Palermo, Italy

An integrated approach using hydrodynamic and transport numerical models, lepidochronology and stable isotope analysis was used to investigate how local hydrodynamic conditions influence the primary production and fate of the seagrass *Posidonia oceanica* in a Mediterranean semi-enclosed marine system (Stagnone di Marsala). The water mass exchange aptitude of different sectors of the basin was analysed, and data collected were used to select two sectors (colonized by *Posidonia oceanica* showing the lowest and highest water exchange values) for biological analyses. According to the mean dispersal coefficient differences simulated by the hydrodynamic model, growth rate and primary production of *P. oceanica* differed between sectors, with average values lower in the central sector where water exchange is lower than in the southern sector. Although *P. oceanica* coverage and primary production were higher in the southern sector, carbon and nitrogen stable isotope analysis suggests that the transfer of seagrass organic matter to higher trophic levels of the food web was higher in the central sector. The possibility of a link between hydrodynamism, production and fate of organic matter is proposed to explain the observed patterns.

Keywords: Water exchange; Numerical models; *Posidonia oceanica*; Lepidochronology; Stable isotopes; Mediterranean

## 1 INTRODUCTION

Seagrass ecosystems are characterized by a high productivity and ecological complexity (Den Hartog, 1977; Hemminga and Duarte, 2000). They provide habitat and food for invertebrates and fish, and modulate sedimentary and biogeochemical processes (McRoy and Helfferich, 1977).

In benthic communities, water dynamics can affect functional and structural features (Steever et al., 1976; Fonseca et al., 1983; Worcester, 1995) and also regulate organic-matter availability and fate (Deegan and Garritt, 1997). Hydrodynamics control other physical and chemical factors such as temperature and salinity, which can affect sea-

Corresponding author. E-mail: [glal@idra.unipa.it](mailto:glal@idra.unipa.it)



grass metabolism and distribution (Short and Neckles, 1999). In particular, small variations of these physical- chemical factors may limit growth and distribution of seagrass standing in habitats under stress conditions of temperature and salinity (Flowers, 1985; Short and Neckles, 1999).

In the Mediterranean, *Posidonia oceanica* (L.) Delile is a valuable biotic component of the littoral zone and contributes significantly to primary production (Cebrián and Duarte, 2001) with almost 3499 million tons of carbon produced annually (Pergent et al., 1997). While it has been found that *P. oceanica* is able to reduce particle resuspension under low energy conditions and to generate turbulence (Terrados and Duarte, 2000), there is little knowledge in the field of the quantitative influence of hydrodynamic phenomena on its distribution, production and fate (Balzano et al., 2000).

Recently, more attention has been paid to the use of reconstructive ageing techniques as powerful tools for investigating the effects of natural constraints in littoral areas colonized by seagrasses (Guidetti, 2000). These methods provide reliable estimates of seagrass production when used for studying phenomena at annual or longer timescales (Duarte et al., 1994). In *P. oceanica*, lepidochronology appears to be a particularly effective tool to evaluate growth rate and primary production of the rhizome (Pergent, 1990). In addition, this method allows a more accurate estimate of leaf formation and leaf primary production than the commonly employed reconstructive ageing techniques (Guidetti, 2000).

The fate of organic matter in *P. oceanica* systems is difficult to assess as a consequence of the high number of primary producers (i.e. vascular plants, macroalgae, benthic and pelagic microalgae), high connectance and omnivory (Mazzella et al., 1992). In this context, the analysis of stable carbon and nitrogen isotope ratios is a useful tool for investigating trophic structure and feeding relationships between producers and consumers in detrital and coastal food webs (Michener and Schell, 1994). The utility of such measurements lies in the predictable variations in the transfer of carbon and nitrogen isotopes throughout the food webs. Accordingly, the carbon isotope ratios of animals reflect those of their food sources plus a slight enrichment (about 1‰; Fry and Sherr, 1984), while nitrogen undergoes a greater fractionation, increasing by about 3.5‰ (Minagawa and Wada, 1984). Several isotopic studies have been carried out in seagrass ecosystems (Fry, 1984; Dauby, 1989; Jennings et al., 1997; Lepoint et al., 2000; Pinnegar and Polunin, 2000; Vizzini et al., 2002a, b) and most of the recent literature has emphasized a greater role of algae compared to vascular plants. In addition, stable isotope studies have suggested that the structure of food webs is often site-specific, subject to extremely complex dynamics and influenced by many factors (i.e. the nature of the organic matter and environmental features such as hydrodynamic conditions) (Deegan and Garritt, 1997; Jennings et al., 1997). The hydrology influences the production and availability of producers: a high level of water exchange increases the production and transport of vascular plants, while a low level of water exchange determines the retention of in situ primary production (Steever et al., 1976; Peterson et al., 1986).

Thus, the implementation of hydrodynamic models, taking into account components dominating the energy fluxes (tidal and wind), can increase our understanding of production, fate and forecasting of the evolution of the system.

In this context, the main aim of this paper was to investigate how water-exchange local conditions influence the primary production and fate of the seagrass *P. oceanica* in a semi-enclosed marine system (Stagnone di Marsala, western Sicily) using an integrated approach (i.e. hydrodynamic and transport numerical model, lepidochronology and stable isotope analysis).



## 2 MATERIALS AND METHODS

### 2.1 Study Area

The Stagnone di Marsala is a coastal basin in western Sicily ( $37^{\circ}52'N$ ;  $128^{\circ}28'E$ , Fig. 1) about  $20\text{ km}^2$  in area and geomorphologically divided into two sub-basins. The northern sub-basin ( $14\text{ km}^2$ , mean depth  $1\text{ m}$ ) and the southern sub-basin ( $6\text{ km}^2$ , mean depth  $2\text{ m}$ ) are separated by a *P. oceanica* barrier reef (Calvo and Frada` Orestano, 1984). Water exchange with the open sea occurs through two openings: the northern opening is much narrower and shallower than the southern opening. The northern sub-basin shows greater lagoon characteristics and a higher annual variability of temperature and salinity than the southern basin (Sara` et al., 1999), where a higher hydrodynamic regime is observed. No freshwater input is present (Sara` et al., 1999). Nutrients are present in low concentrations in all sectors of the lagoon (Maimone et al., 1998), and the trophic response, in terms of chlorophyll a concentration ( $1.0\text{ mg l}^{-1}$ ), identifies the lagoon as oligotrophic (Sara` et al., 1999).

Within the Stagnone, the main biotic component is represented by *P. oceanica* meadow; this covers the central and southern regions of the northern sub-basin and shows a patch

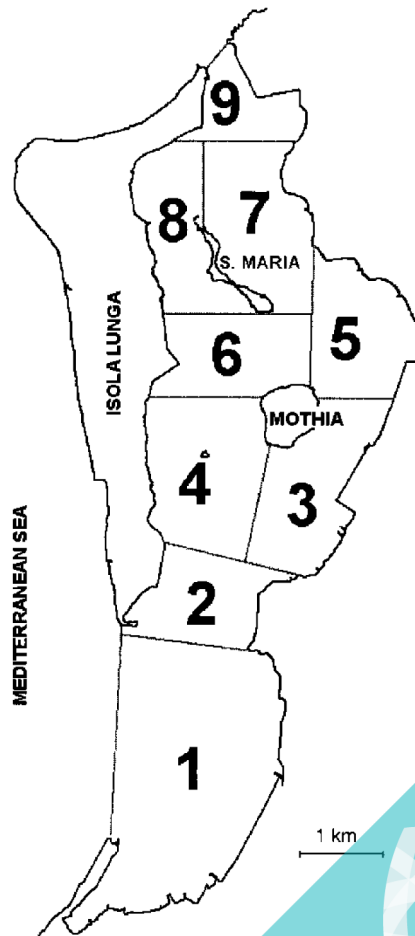

FIGURE 1 Study area (Stagnone di Marsala) with sampling sectors

distribution, representing about 12% of the total coverage (Calvo et al., 1996; 2003). Distinctive formations of *P. oceanica* are present in the northern sub-basin: “atoll” patterns (10 – 20 m in diameter) gradually closing in reef formations (1 – 2 m wide) along the north-south direction. Within the lagoon, *P. oceanica* meadow is regressing, and dead “matte” is frequent (Calvo and Frada` Orestano, 1984). Where hydrodynamic conditions and sediment composition worsen for *P. oceanica*, the seagrass meadow is partially replaced by *Cymodocea nodosa* (Ucria) Asch. and *Caulerpa prolifera* (Forssk) Lam. prairies.

Zooplankton constitutes a quantitatively scant group, and, as a consequence of the shallowness and hydrodynamic processes (sediment and bottom organism resuspension), Copepoda Harpacticoida represents the main taxon followed by Copepoda Calanoida (Campolmi, 1998). Regarding the ichthyofauna, *Atherina boyeri* Risso (Atherinidae), *Syngnathus abaster* Risso, *S. typhle* L. (Syngnathidae), *Pomatoschistus tortonesei* Mill. and *Gobius niger* L. (Gobiidae) are the main resident fish, while *Liza aurata* Risso (Mugilidae), *Sarpa salpa* L. and *Diplodus puntazzo* Cetti (Sparidae) are the most abundant transient fish (Scilipoti, 1998). Resident species are known to be carnivores feeding on small epifauna and detritivores, while juveniles of transient species are mainly zooplanktivores (Scilipoti, 1998; Vizzini et al., 2002b).

## 2.2 Sampling Areas

The northern sub-basin of the Stagnone di Marsala lagoon is characterized by a high spatio-temporal environmental variability (Pusceddu et al., 1997; Scilipoti, 1998; Mazzola et al., 1999; Sara` et al., 1999). In particular, previous studies using both biological and morphological observations have established that differential circulation patterns occur within this sub-basin (Mazzola and Sara`, 1995; Campolmi, 1998; Sara` et al., 1999). Since no study has been carried out on the water mass exchange aptitude of different areas of the Stagnone, in this paper we examined this aptitude in nine sectors selected by analysing previous publications (Calvo et al., 1996; Mazzola et al., 1999; Sara` et al., 1999). Following the preliminary indication of the hydrodynamic simulations (Balzano et al., 2000; 2002; Ciralo, 2000), the two sectors colonized by *P. oceanica* showing extreme values of water exchange, respectively the 2nd and 5th, were selected for biological and isotopic analysis (Fig. 1). The depth of both sectors was about 1 m.

### 2.2.1 Hydrodynamic and Transport Models

**2.2.1.1 Hydrodynamic Model (HD)** Within the lagoon, water flows mainly in the horizontal direction (owing to the shallowness of water; Abbot and Cunge, 1975; ASCE, 1988; Casulli, 1990); this allows a two-dimensional hydrodynamic depth-averaged model to be applied (Kowalik and Murty, 1993).

Water-flow fields due to tide (in the Stagnone lagoon, the tidal excursion is about 30 cm) and wind stresses can be calculated by the numerical solution of vertically integrated momentum and continuity equations (shallow water equations, SWE; MIKE 21, 2000): momentum equation in direction x:

$$\frac{\partial p}{\partial t} + \frac{\partial}{\partial x} \left( \frac{p^2}{h} \right) + \frac{\partial}{\partial y} \left( \frac{pq}{h} \right) + gh \frac{\partial \zeta}{\partial x} + \frac{gp\sqrt{p^2 + q^2}}{C^2 h^2} - \frac{1}{\rho_w} \left[ \frac{\partial}{\partial x} (h\tau_{xx}) + \frac{\partial}{\partial y} (h\tau_{xy}) \right] +$$

$$- \Omega p - f VV_x + \frac{h}{\rho_w} \frac{\partial}{\partial x} (p_a) = 0,$$

momentum equation in direction y:

$$\frac{\partial q}{\partial t} + \frac{\partial}{\partial y} \left( \frac{q^2}{h} \right) + \frac{\partial}{\partial x} \left( \frac{pq}{h} \right) + gh \frac{\partial \zeta}{\partial y} + \frac{gp\sqrt{p^2 + q^2}}{C^2 h^2} - \frac{1}{\rho_w} \left[ \frac{\partial}{\partial y} (h\tau_{yy}) + \frac{\partial}{\partial x} (h\tau_{xy}) \right] + \Omega p - f V V_y + \frac{h}{\rho_w} \frac{\partial}{\partial y} (p_a) = 0,$$

continuity equation:

$$\frac{\partial \zeta}{\partial t} + \frac{\partial p}{\partial x} + \frac{\partial q}{\partial y} = 0,$$

where:  $h(x,y,t)$  is the water depth (m);  $z(x,y,t)$  is the surface elevation (m);  $p, q, (x,y,t)$  are flux densities in  $x$  and  $y$  directions ( $m^3 s^{-1} m^{-1}$ ) ( $uh, vh$ );  $(u, v)$  are depth-averaged velocities in directions  $x$  and  $y$ ;  $C(x, y)$  is the Chezy resistance ( $m^{1/2} s^{-1}$ );  $g$  is acceleration due to gravity ( $m s^{-2}$ );  $f(V)$  is the wind friction factor;  $V, V_x, V_y, (x, y, t)$  are the wind speed and components in  $x$  and  $y$  directions ( $m s^{-1}$ ), respectively;  $V(x, y)$  is the Coriolis parameter ( $s^{-1}$ );  $p_a(x, y, t)$  is atmospheric pressure ( $kg m^{-2}$ );  $\rho_w$  is water density ( $kg m^{-3}$ );  $x, y$  are the spatial coordinates (m);  $t$  is the elapsed time (s);  $\tau_{xx}, \tau_{xy}, \tau_{yy}$  are the components of effective shear stress. The solution of these equations in a spatial domain is possible under prescribed initial and boundary conditions. The output of the solution is velocities and total depth (sum of mean depth and surface elevation) for each point of computational domain.

**2.2.1.2 Advection Dispersion Model (AD)** Similarly, a two-dimensional advection dispersion transport model was used to simulate the distribution of dissolved or suspended substances. The transport equation represents the mass conservation principle and can be written as (MIKE 21, 2000):

$$\frac{\partial}{\partial t} (hC) + \frac{\partial}{\partial x} (uhC) + \frac{\partial}{\partial y} (vhC) = \frac{\partial}{\partial x} \left( hD_x \frac{\partial C}{\partial x} \right) + \frac{\partial}{\partial y} \left( hD_y \frac{\partial C}{\partial y} \right) - FhC + Q_s(C_s - C),$$

where:  $C$  (arbitrary units) is the concentration of a generic passive solute;  $u, v$  ( $m s^{-1}$ ) are the horizontal velocity components in the directions  $x$  and  $y$ ;  $h$  is the water depth (m);  $D_x, D_y$  ( $m^2 s^{-1}$ ) is the dispersion coefficient in the  $x, y$ , directions;  $F$  ( $s^{-1}$ ) is the linear decay coefficient;  $Q_s$  ( $m^3 s^{-1} m^{-2}$ ) is the source/sink discharge;  $C_s$  is the concentration in the source or sink discharge.

The  $u, v$  and  $h$  quantities are computed, for each time step, by the hydrodynamic section of the program. The software we used to solve and apply the previous equations to our study area is MIKE 21, a two dimensional finite difference software produced by the DHI (Danish Hydraulic Institute).

MIKE 21 HD (Hydrodynamic) uses the so-called Alternating Direction Implicit (ADI) technique to integrate the equation for mass and momentum conservation in the space and time domain (Stelling et al., 1986). The hydrodynamic equations of the model are discretized on a fully staggered grid (Fig. 2) where scalar quantities (e.g. water levels) are defined in the grid nodes, and velocities are defined in the middle of two grid nodes (MIKE 21, 2000).

Time-centring of the three HD equations is implemented using a fractional step method. Regarding the Advection Dispersion numerical model, MIKE 21 AD (Advection Dispersion)

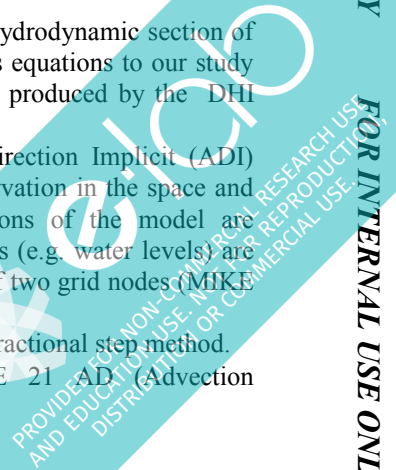

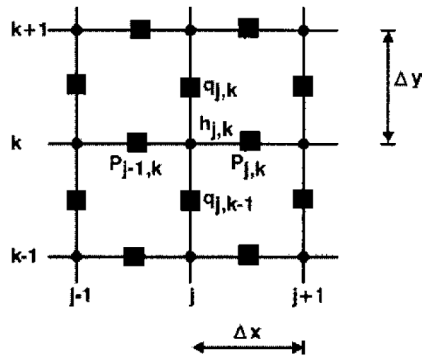

FIGURE 2 Staggered grid of numerical model.

solves the mass conservation of a suspended or dissolved substance using a two-dimensional schema of QUICKEST discretization method (Leonard, 1979).

The advection dispersion equation is solved using a third-order explicit finite difference method suggested by Ekebjærg and Justesen (1991). This method has many advantages over the other methods avoiding the typical instability problems of centred difference methods of the advective terms (the so-called “wobble”); at the same time, this method reduces the numerical damping typical of the first-order upwind methods.

In order to find a coefficient useful to characterize the aptitude of water mass exchange of a fixed point of the lagoon, we adopted the “Intertidal Dispersion Coefficient” (Casulli and Cheng, 1992; Cheng and Casulli, 1992; Adami et al., 1997). The definition of this coefficient comes from the observation that if we release a tracer (passive) continuously from a fixed point of the water body, after a tidal cycle the size area covered by this dispersed tracer (dispersion figure) will be greater the greater the water mass exchange. If we calculate the equivalent radius,  $r$  (m), of the dispersion figure, we can define the “Intertidal Dispersion Coefficient” (IDC) as:

$$IDC \frac{1}{4} r^2 = T (m^2 s^{-1}),$$

where  $T$ (s) is the period of the tidal cycle. The IDC parameter is a coefficient that is useful for characterizing the attitude of dispersion of a point in the water body without regarding the variation of the forcing terms (wind and tide). Where the IDC assumes high values, the water exchange is strong (thus, the residence time is short).

For this study, the lagoon was discretized into a square 100 m grid. Data coming from bathymetric surveys were interpolated to generate a digital elevation model for the bottom. Furthermore, tidal cycles were defined by the harmonic analysis of one year’s data (Ciraolo, 2000).

To compute the IDC in 40 points of the lagoon, 40 simulations with semi-diurnal tidal forcing (period  $T \frac{1}{4} 12$  h) have been performed. Each run, lasting 48 h, simulated the effects of tide over the physical system. Outputs were recorded after the 36th hour to consider negligible the effects of zero initial velocity field values.

The diffusive terms of the AD module have been set to zero to take into account only the convective transport effect. For each run, a concentration of 10,000 has been released at the 36th hour from each point chosen for the IDC evaluation (the unit of concentration is not important). A concentration of 0 has been set elsewhere. At the end of each run, the dispersion figure has been evaluated, counting the number of cells with a concentration greater than zero.

## 2.2.2 Primary Production of *P. oceanica*

To assess the effect of different water exchange conditions on density and primary production of *P. oceanica*, sampling was carried out in the two selected sectors (2 and 5). In the sampling area, the meadow shows reef formations, and leaves emerge during the low tide.

Three sites (900 m<sup>2</sup> wide, 1 m deep) were randomly selected within each sector. At each site, 10 orthotropic rhizomes, with a distance of at least 1 m from each other (Pergent et al., 1983), were randomly collected by scuba diving in November 2000. Moreover, 10 orthotropic rhizomes with living foliar shoots were sampled quarterly from November 2000 to September 2001 for phenological study. The samples were preserved in a 4% formalin seawater solution for laboratory observations.

Shoot density was determined in situ using a 40 × 40 cm quadrat with four replicates per site.

For each foliar shoot, leaves were stripped in distichous order of insertion. The total length and width of each leaf and the length of the sheath, when present, were measured. The leaves were separated into the various categories defined by Giraud (1979). The adult leaves of rank

1 (the oldest) were scraped with a razor blade to remove epiphytes, dried at 70 °C to constant weight and weighed after separating the blade and sheath (Pergent, 1990).

For each rhizome, the cyclic variation of the sheath thickness was analysed to isolate and date rhizome segments corresponding to a one-year period, determined between each pair of sheaths of minimum thickness ('lepidochronological year' according to Pergent, 1990). In addition, they were dried to constant weight at 70 °C to estimate primary rhizome production (Pergent, 1990).

Past primary leaf production (PI) was estimated according to the Pergent and Pergent-Martini (1991) method, by applying the formula:

$$PI = \frac{1}{4} N \cdot D \cdot L,$$

where:  $N = \frac{1}{4}$  mean number of leaves (lepidochronological data);  $D = \frac{1}{4}$  leaf density (phenological data) corresponding to leaf weight by unit of length (Sand-Jensen, 1975);  $L = \frac{1}{4}$  mean leaf length (lepidochronological data) estimated using the ratio between the length of sheath persisting on the rhizome and their fallen overall leaf length (Giraud, 1979; Pergent and Pergent-Martini, 1991). All the lepidochronological parameters were estimated for the year 1998.

The slope and intercept of the morphometric relationship between sheath length and overall leaf length were estimated by least-squares linear regression applied to phenological data. The Durbin – Watson statistic was applied to test the existence of a serial correlation of the adjacent error term in regression analysis (Underwood, 1997) by using critical values at 5%, as reported in Savin and White (1977).

A hierarchical analysis of variance (nested ANOVA) was performed to test the difference among sectors in number of leaves per cycle, rhizome primary production and growth, foliar and total primary production, and shoot density. 'Sector' was considered a fixed factor, while the factor 'site' was random and nested in 'Sector'. A preliminary test for homogeneity of variance (Cochran's test) was performed to execute, if necessary, an appropriate transformation of the data set (Underwood, 1997).

## 2.3 Isotopic Analysis

Sampling was carried out in November 1998 in the selected sectors (2 and 5). Samples of seawater were filtered through precombusted glass-fibre filters (Whatman GF/F) (450 °C, 4 h) for the isotopic analysis of suspended particulate organic matter (POM). Sediment samples, collected using hand corers, were analysed to measure the carbon and nitrogen isotope ratios in the sedimentary organic matter (SOM). Common macroalgae were



picked by hand together with the seagrass *P. oceanica*. Vagile epifauna was caught by means of a hand-towed net (mesh size: 400 mm), while zooplankton was sampled by towing a net (mesh size: 125 mm) for about 10 min. A hand-towed trawl net (mesh size: 3 mm) was used to catch fish. Six replicates were collected for each food web component in both sectors.

In the laboratory, after acidification in 2 N HCl, all samples were dried at 60 °C to constant weight and ground. Because of the wide variation in the isotopic composition of plants (Michener and Schell, 1994) and to avoid within- and among-individual variability, each plant sample consisted of five to 10 individuals. All invertebrate and fish samples were obtained by pooling several individuals (~100 for small invertebrates and about 10 for *Palaemon* sp., *Asterina gibbosa* and fish). Invertebrate specimens were analysed whole, while only the muscle of fish, which is known to be less variable in  $\delta^{13}\text{C}$  and  $\delta^{15}\text{N}$  than all other tissues (Pinnegar and Polunin, 1999), was analysed after dissection. The carbon and nitrogen stable-isotope ratios were analysed using a Finnigan Delta-S isotope ratio mass spectrometer. Isotopic values were expressed in parts per thousand (‰) as deviations from standards (Vienna Pee Dee Belemnite for  $\delta^{13}\text{C}$  and nitrogen in air for  $\delta^{15}\text{N}$ ) according to the following formula:

$$\delta^{13}\text{C} \text{ or } \delta^{15}\text{N} \text{ (‰)} = \left( \frac{R_{\text{sample}}}{R_{\text{standard}}} - 1 \right) \times 10^3, \text{ where } R^{13}\text{C} = \frac{^{13}\text{C}}{^{12}\text{C}} \text{ or } R^{15}\text{N} = \frac{^{15}\text{N}}{^{14}\text{N}}$$

Experimental precision based on the standard deviation of replicates of internal standards was 0.2‰ for both  $\delta^{13}\text{C}$  and  $\delta^{15}\text{N}$ .

A linear mixing model (see Dauby, 1989 for details), used for the identification of the origin of POM and SOM, yielded the possible contribution from three main sources (sea-grass, macroalgae and phytoplankton) to total suspended particulate and sedimentary organic matter. Reference isotopic signatures were used for phytoplankton (Dauby, 1989). Spatial differences in the isotopic composition ( $\delta^{13}\text{C}$  and  $\delta^{15}\text{N}$ ) were tested using a t-test (Sokal and Rohlf, 1995). Multivariate techniques were used to analyse spatial patterns in the isotopic composition of organic-matter sources and consumers (Clarke and Warwick, 1994). Triangular similarity matrices were constructed using normalized Euclidean distances. Ordination was by non-metric multidimensional scaling (nMDS). Multivariate analyses were performed using PRIMER (Plymouth Marine Laboratory, UK; Clarke and Warwick, 1994).

### 3 RESULTS

#### 3.1 The Hydrodynamic and Transport Model

Results of the simulations are shown in Figure 3. In addition to individual values, for each sector the values of IDC have been averaged. In general, the southern part of the lagoon was characterized by high IDC values (about 22  $\text{m}^2 \text{ s}^{-1}$ ). Moving north, sectors 3, 4 and 6 were characterized by similar values. The lowest exchange was found in sector 5 (North East of Mothia). The area of Santa Maria island also had low values. Finally, the 9th sector showed slightly elevated values compared to sectors 7 and 8.

#### 3.2 Primary Production of *P. oceanica*

The relationship between sheath and total length of *P. oceanica* leaves from the two sectors investigated was  $y = 25.50 - 6.38x^2$  ( $R^2 = 0.58$ ,  $P < 0.01$ ). The Durbin-Watson statistic did not show any residual autocorrelation (DW = 1.677,  $n = 95$ ). On the basis of this equation, a lower mean leaf length was obtained at sector 5, where the mean value was 26.7 cm. In contrast, sector 2 showed mean values of 38.9 cm.

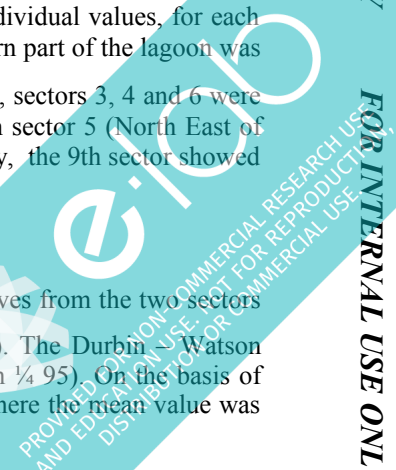

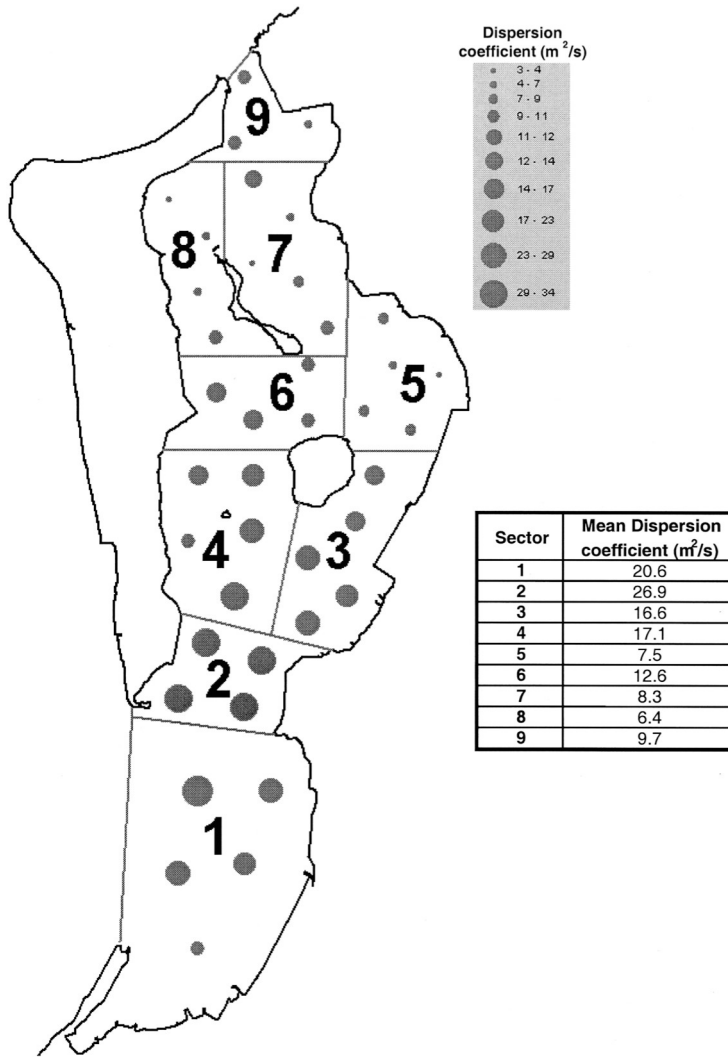

FIGURE 3 IDC distribution for each sector.

The mean number of leaves, calculated on the basis of the number of sheaths per lepidochronological cycle, ranged from 5 to 8 (mean value  $6.3 \pm 0.9$ ) for sector 5 and from 6 to 8 (mean value  $7.2 \pm 0.7$ ), for sector 2 (Tab. I). Leaf density (blades plus sheaths) ranged from  $3.4 \pm 0.1 \text{ mg dw cm}^{-2}$  (sector 5) to  $4.4 \pm 0.1 \text{ mg dw cm}^{-2}$  (sector 2). The mean sheath length was  $3.32 \pm 0.51 \text{ cm}$  (sector 5) and  $5.23 \pm 0.36 \text{ cm}$  (sector 2).

The estimation of the past leaf primary production per shoot showed values ranging from  $0.57 \pm 0.12 \text{ g dw shoot}^{-1} \text{ yr}^{-1}$  (sector 5) to  $1.24 \pm 0.13 \text{ g dw shoot}^{-1} \text{ yr}^{-1}$  (sector 2) (Tab. I). Rhizome growth rate showed the lowest values at sector 5 (mean value  $4.3 \pm 1.5 \text{ mm shoot}^{-1} \text{ yr}^{-1}$ ), while the growth rate at sector 2 was  $12.8 \pm 5.0 \text{ mm shoot}^{-1} \text{ yr}^{-1}$ . The same pattern was observed for rhizome primary production, ranging from  $0.03 \pm 0.02 \text{ g dw shoot}^{-1} \text{ yr}^{-1}$  at sector 5 to  $0.15 \pm 0.06 \text{ g dw shoot}^{-1} \text{ yr}^{-1}$  at sector 2. In addition, the primary total production was calculated, and values of  $0.6 \pm 0.13 \text{ g dw shoot}^{-1} \text{ yr}^{-1}$  at sector 5 and  $1.39 \pm 0.17 \text{ g dw shoot}^{-1} \text{ yr}^{-1}$  at sector 2 were observed. The shoot density of *P. oceanica* showed values varying from  $196.9 \pm 42.7 \text{ shoots m}^{-2}$  at sector 5 to  $337.5 \pm 97.5 \text{ shoots m}^{-2}$  at sector 2.

PROOF  
 PROVIDED FOR NON-COMMERCIAL RESEARCH USE  
 AND PUBLICATION. NOT FOR REPRODUCTION OR DISTRIBUTION FOR COMMERCIAL USE

TABLE I Mean values of the examined variables and significant levels in ANOVA (with standard deviations in parentheses).

	Sector		F	P
	2	5		
Leaf formation (leaves shoot <sup>21</sup> yr <sup>21</sup> )	7.2 (0.7)	6.3 (0.9)	6.9	n.s.
Leaf primary production (g dw shoot <sup>21</sup> yr <sup>21</sup> )	1.24 (0.13)	0.57 (0.12)	114.8	
Growth rate (mm shoot <sup>21</sup> yr <sup>21</sup> )	12.8 (5.0)	4.3 (1.5)	23.8	
Rhizome primary production (g dw shoot <sup>21</sup> yr <sup>21</sup> )	0.15 (0.06)	0.03 (0.02)	39.8	
Total primary production (g dw shoot <sup>21</sup> yr <sup>21</sup> )	1.39 (0.17)	0.60 (0.13)	82.5	
Shoot density (shoots m <sup>2</sup> )	337.5 (97.5)	196.9 (42.7)	16.0	

Note: n.s.: not significant (P > 0.05).  
 P < 0.05; P < 0.01.

ANOVA provided statistical difference for all variables except for leaf formation (Tab. I). Leaf primary production values ranged from 112.1 to 417.4 g dw m<sup>-2</sup> yr<sup>-1</sup>, respectively, for sectors 5 and 2. The mean values of rhizome primary production were 5.5 g dw m<sup>-2</sup> yr<sup>-1</sup> at sector 5 and 51.9 g dw m<sup>-2</sup> yr<sup>-1</sup> at sector 2. Finally, total primary production showed mean values varying from 117.6 g dw m<sup>-2</sup> yr<sup>-1</sup> to 469.3 g dw m<sup>-2</sup> yr<sup>-1</sup>, at sector 5 and sector 2, respectively (Fig. 4). Given the *Posidonia* coverage (Calvo et al., 1996) and its primary production per unit area, it was possible to calculate global primary production of the meadow at the two sectors (Bergent et al., 1997). This was estimated as 9.9 tons dw yr<sup>-1</sup> at sector 5 and 85.6 tons dw yr<sup>-1</sup> at sector 2 (Tab. II).

### 3.3 Isotopic Analysis

The carbon isotope ratios of organic-matter sources were found to range from 28.0 + 0.1‰ (*Cymodocea nodosa*) to 220.6 + 0.5‰ (*Chaetomorpha linum*) in sector 5 and from 27.3 + 0.1‰ (*C. nodosa*) to 220.2 + 0.5‰ (POM) in sector 2 (Tab. III).  
 Regarding <sup>15</sup>N values in both sectors, the most depleted signatures were shown by *P. oceanica* leaf

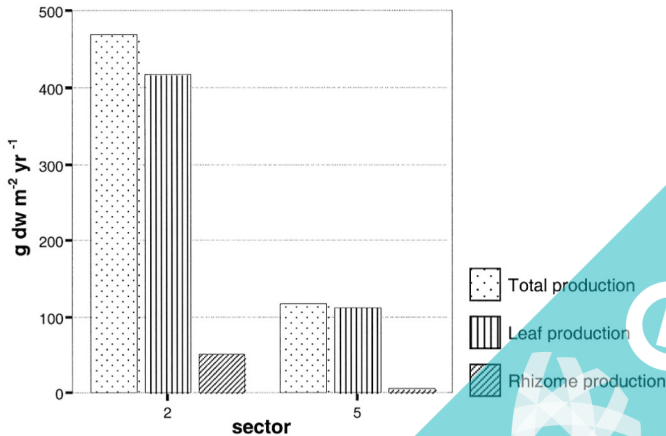

FIGURE 4 Primary production of *Posidonia oceanica* in the Stagnone di Marsala.

TABLE II Primary production of *Posidonia oceanica* meadows.

Sector	Leaf <sup>21</sup> (g dw m <sup>-2</sup> yr <sup>-1</sup> )	Rhizome <sup>21</sup> (g dw m <sup>-2</sup> yr <sup>-1</sup> )	Total <sup>21</sup> (g dw m <sup>-2</sup> yr <sup>-1</sup> )	Posidonia covering (ha)	Total production (ton dw yr <sup>-1</sup> )
2	417.4	51.9	469.3	18.2	85.6
5	112.1	5.5	117.6	8.5	9.9

litter ( $2.4 \pm 0.2\%$  and  $2.1 \pm 0.7\%$ , respectively, in sectors 5 and 2), while the most enriched were shown by *Caulerpa prolifera* ( $8.7 \pm 0.2\%$  and  $9.4 \pm 0.7\%$ , respectively, in sectors 5 and 2).

Consumers showed a narrower range of variations for carbon isotope ratios than organic-matter sources (Tab. III). In particular,  $\delta^{13}\text{C}$  ranged between  $29.5 \pm 0.2\%$  (*Syngnathus abaster*) and  $28.4 \pm 0.2\%$  (*Liza aurata*) in sector 5 and between  $29.4 \pm 0.1\%$  (*Polychaeta*) and  $220.0 \pm 0.2\%$  (*L. aurata*) in sector 2. The  $\delta^{15}\text{N}$  signatures for the consumers collected in sector 5 ranged from  $4.3 \pm 0.5\%$  (*Harpacticoida*) to  $13.2 \pm 0.2\%$  (*Pomatoschistus tortonesei*), and values for samples collected in sector 2 ranged from  $4.4 \pm 0.3$  (*Harpacticoida*) to  $14.5 \pm 2.0\%$  (*Aphanius fasciatus*).

Overall, organic-matter sources showed more  $^{13}\text{C}$ -depleted values in sector 5 than in sector 2 and vice versa for the  $\delta^{15}\text{N}$  values (Tab. III, Fig. 5). The pattern is reversed for both invertebrates and fish, which showed  $^{13}\text{C}$ -enriched and  $^{15}\text{N}$ -depleted values in sector 2 (Tab. III, Fig. 5). Concerning spatial variations, t-test results showed that 13 and 10 of a total of 16 organic-matter sources analysed exhibited significant differences for  $\delta^{13}\text{C}$  and  $\delta^{15}\text{N}$ , respectively, and 12 and 11 of a total of 15 consumer species (Tab. III).

The outcomes of the mixing-model equations revealed a different contribution of main organic-matter sources (i.e. seagrasses, macroalgae and phytoplankton) to SOM and POM (Tab. IV). While SOM seems to be a mixture of seagrass (48%), macroalgae (32%) and phytoplankton (20%) in both the sampling sectors, POM exhibited site-specific differences. POM seems to be mainly affected by macroalgae (48%) and, to a lesser extent, by seagrass (23%) and phytoplankton (29%) in sector 5, and almost exclusively by phytoplankton (84%) in sector 2 (Tab. IV). nMDS ordinations performed on  $\delta^{15}\text{N}$  and  $\delta^{13}\text{C}$  data markedly differentiated between the two sampling sectors (Fig. 6).

#### 4 DISCUSSION

The application of the mathematical finite-difference hydrodynamic model shows how the southern part of the lagoon is characterized by high IDC values (about  $22 \text{ m}^2 \text{ s}^{-21}$ ). This is because the southern basin exchanges with the open sea. Similar values of IDC were obtained for the Venice lagoon (Adami et al., 1997). Following the geomorphology of the Stagnone lagoon, sector 2 showed higher values because it is the hydraulic connection between the two sub-basins. Going to the north, sectors 3, 4 and 6 were characterized by similar values: this means that these areas are similar from a hydrodynamic point of view. The lowest exchange was found in sector 5 (North East of Mothia), since the morphology and the presence of the ancient Punic road restrict the possibility of circulation: the same conclusion was reached in a previous qualitative study (Mazzola and Sara, 1995). The area of Santa Maria island (sectors 7 and 8) showed low values: this is because this area represents a sort of “inactive zone” from the hydrodynamic point of view. Finally, the 9th sector showed slightly elevated values compared to sectors 7 and 8, but being an open sea connection, a higher exchange might be expected: the reason for this discrepancy is that the opening is both shallow

TABLE III Carbon and nitrogen isotope ratios (+S.D.;‰) of organic matter sources and consumers in the to sampling sectors and the significance levels of the t-test (d.f. 1/4 10) performed to evaluate differences in the isotopic composition between sectors.

Group	Species	ACR	Sector 5				Sector 2				$\delta^{13}C$	$\delta^{15}N$
			$\delta^{13}C$	S.D.	$\delta^{15}N$	S.D.	$\delta^{13}C$	S.D.	$\delta^{15}C$	S.D.	t-value (P)	t-value (P)
Green algae	<i>Anadyomene stellata</i>	–	–16.1	0.2	2.8	0.2	–14.1	0.3	8.3	2.4	–13.97 (***)	–6.36 (***)
	<i>Caulerpa prolifera</i>	–	–15.8	0.1	8.7	0.2	–14.2	0.2	9.4	0.7	–18.75 (***)	–5.72 (***)
	<i>Chaetomorpha linum</i>	–	–20.6	0.5	8.3	0.2	–18.1	0.1	6.0	0.5	–10.86 (***)	6.60 (***)
	<i>Dasycladus vermicularis</i>	–	–18.4	0.2	6.4	0.1	–18.5	0.2	6.2	0.2	0.21 (n.s.)	1.88 (n.s.)
	<i>Halimeda tuna</i>	–	–16.4	0.2	8.3	0.2	–16.4	0.2	8.1	0.3	0.00 (n.s.)	0.15 (n.s.)
	<i>Valonia utricularis</i>	–	–17.2	0.2	6.3	0.1	–17.2	0.2	2.7	1.1	0.00 (n.s.)	6.83 (***)
Brown algae	<i>Cystoseira spinosa</i>	–	–17.2	0.1	5.9	0.0	–16.0	0.2	2.7	1.0	–13.11 (***)	6.63 (***)
Red algae	<i>Chondria</i> sp.	–	–18.9	0.1	6.4	0.2	–18.3	0.1	5.9	0.1	–13.50 (***)	3.98 (**)
	<i>Rytiphlaea tinctoria</i>	–	–19.5	0.1	7.9	0.1	–19.2	0.2	8.1	0.5	–3.15 (*)	–3.48 (**)
Phanerogam	<i>Cymodocea nodosa</i>	–	–8.0	0.1	6.0	0.1	–7.3	0.1	5.3	0.0	–11.07 (***)	5.90 (***)
	<i>C. nodosa</i> leaf litter	–	–9.9	0.1	2.3	0.2	–9.4	0.1	0.9	0.4	–5.88 (***)	6.40 (***)
	<i>Posidonia oceanica</i>	–	–10.7	0.2	2.8	0.5	–9.5	0.1	2.1	0.7	–11.46 (***)	1.55 (n.s.)
	<i>P. oceanica</i> leaf litter	–	–9.6	0.4	2.4	0.2	–8.8	0.2	2.1	0.3	–3.85 (**)	2.45 (n.s.)
Epiphytic algae	<i>P. oceanica</i> epiphytes	–	–14.7	0.2	7.9	0.3	–15.1	0.2	7.3	1.1	3.13 (*)	1.09 (n.s.)
	Sedimentary organic matter	SOM	–14.5	0.1	2.6	0.2	–13.8	0.2	5.3	1.1	–7.25 (***)	–6.72 (***)
–	Particulate organic matter	POM	–16.8	0.8	4.4	1.1	–20.2	0.5	3.3	0.6	9.44 (***)	2.02 (n.s.)
Crustacean	Amphipoda (mixed species)	Amp	–15.7	0.9	6.4	0.6	–16.3	0.3	6.7	0.5	1.43 (n.s.)	–1.35 (n.s.)
	Calanoida (mixed species)	Cal	–16.3	0.1	4.7	0.3	–17.5	0.1	6.4	0.9	16.60 (***)	–6.17 (***)
	Harpacticoida (mixed species)	Har	–13.5	0.7	4.3	0.5	–14.3	0.5	4.4	0.3	2.29 (*)	–0.73 (n.s.)
	<i>Palaemon</i> sp.	Pal	–11.9	0.2	11.0	0.1	–9.4	0.1	11.6	0.8	–30.45 (***)	–6.77 (***)
	Tanaidacea (mixed species)	Tan	–14.4	0.1	5.0	0.1	–15.8	0.1	6.4	0.9	25.32 (***)	–5.36 (***)
	Echinoderm	<i>Asterina gibbosa</i>	Ag	–9.7	0.1	10.4	0.1	–13.4	0.2	7.6	0.7	37.14 (***)
Anellid	Polychaeta (mixed species)	Pol	–11.8	0.1	5.4	0.2	–14.4	0.5	7.5	1.1	12.52 (***)	–6.52 (***)
Fish	<i>Aphanius fasciatus</i>	Af	–9.7	0.3	12.2	0.2	–13.6	0.4	14.5	2.0	18.25 (***)	–3.84 (**)
	<i>Atherina boyeri</i>	Ab	–10.7	0.1	11.5	0.6	–11.7	0.3	9.3	1.8	7.16 (***)	2.4 (*)
	<i>Gobius niger</i>	Gn	–11.4	0.1	12.2	0.5	–11.6	0.2	13.4	1.0	2.17(n.s.)	–4.97 (**)
	<i>Liza aurata</i>	La	–18.4	0.2	6.3	0.1	–20.0	0.2	6.9	0.5	14.28 (***)	–5.54 (***)
	<i>Pomatoschistus tortonesei</i>	Pt	–9.7	0.2	13.2	0.2	–11.5	0.1	12.9	0.6	19.18 (***)	0.39 (n.s.)
	<i>Symphodus ocellatus</i>	So	–12.9	0.1	10.4	0.3	–12.8	0.1	6.9	0.8	–1.71 (n.s.)	6.79 (***)
	<i>Syngnathus abaster</i>	Sa	–9.5	0.2	12.3	0.6	–11.4	0.2	12.8	0.9	14.68 (***)	–2.01 (n.s.)
	<i>Syngnathus typhle</i>	St	–10.1	0.3	9.8	0.4	–11.5	0.1	10.7	0.8	10.17 (***)	–4.63 (**)

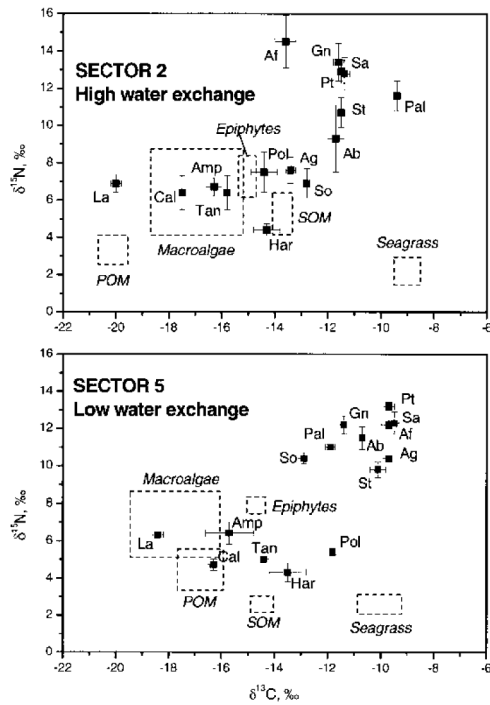

13 15

FIGURE 5  $\delta^{13}\text{C}$  vs.  $\delta^{15}\text{N}$  (+S.D.; ‰) for organic matter sources (dashed squares) and consumers from the two sampling sectors. For acronyms, see Table III.

(30 cm) and narrow (400 m). In fact, during low tide, much of this area is emergent. In general, one can conclude that the lagoon shows a high water exchange in the southern basin and in the southern part of the northern basin. Going north, the hydrodynamic dispersion activity becomes less significant and the possibility of water exchange reduced.

During the summer season, the lower water exchange, together with shallowness, determines high temperature and salinity values, especially in the central sector of the lagoon (Mazzola and Sara, 1995). Within the Stagnone di Marsala Lagoon, *P. oceanica* lives near to its thermal and salinity tolerance (Calvo et al., 2000), suggesting that water exchange, controlling temperature and salinity factors, can affect *P. oceanica* metabolism and distribution. However, Pergent and Pergent (1988) point out that water movement influences some morphometric variables in *P. oceanica* (e.g. scale thickness increases with greater hydrodynamism).

TABLE IV Linear mixing model results indicating the percentage contribution of each main carbon source to sedimentary (SOM) and suspended particulate (POM) organic matter in the two sampling sectors.

Sector	% seagrass	% macroalgae	% phytoplankton
SOM			
2	48.1 ± 6.7	32.5 ± 18.0	19.3 ± 11.3
5	47.3 ± 5.9	32.5 ± 18.0	20.2 ± 12.3
POM			
2	5.7 ± 1.9	10.0 ± 5.0	84.2 ± 3.1
5	23.1 ± 8.7	47.5 ± 26.7	29.4 ± 17.9

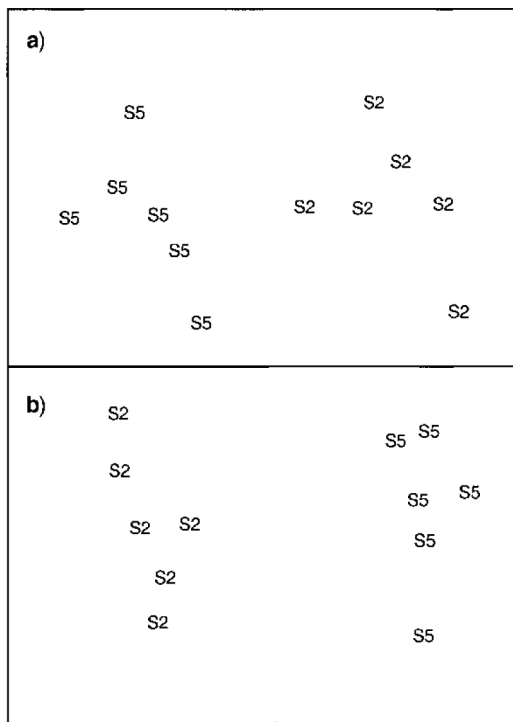

FIGURE 6 Non-metric multidimensional scaling ordinations (n-MDS) of (a) d N and (b) d C values of organic matter sources and consumers based on the normalized Euclidean distance similarity matrix. S5: Sector 5; S2: Sector 2.

Actually, shoot density in the study area is below the range of normal values recorded in other stands in the Mediterranean Sea at the same depth (Pergent et al., 1995), and sector 5 shows the lowest values. Besides, the estimate of total primary production (leaves and rhizomes) also shows that the two populations are below the theoretical value resulting at 1 m depth ( $852.34 \text{ g dw m}^{-2} \text{ yr}^{-1}$ ; Pergent et al., 1997).

In particular, a wide range of growth rate and primary production was found according to sector position, with average values from about three- to 10-fold lower in the inner sector compared to the outer sector. This degree of difference seems to be uncommon in the Mediterranean Sea, considering data collected at comparable depths and geographical locations (Tab. V).

Therefore, in the Stagnone Lagoon, the degree of water exchange seems to affect the shoot density and primary production of the *P. oceanica* meadow. However, no significant variation in annual leaf production was found. This result supports the hypothesis that leaf production along rhizomes is a process determined by a mixture of factors, both internal and external, and may be controlled by an internal biological clock (Molenaar et al., 2000).

Considering stable-isotope analysis performed to investigate the fate of seagrass within the food web, isotopic differences between sectors were observed in the comparison of both organic-matter sources and consumers. Regarding the organic-matter sources, there was a tendency for carbon stable-isotope values to be heavier in the southern sector (sector 2: high water exchange) than in the central sector (sector 5: low water exchange) while the opposite trend was observed for consumers. These differences suggest that organic-matter

TABLE V Leaf and rhizome primary production and growth rate of *Posidonia oceanica* in the Mediterranean basin estimated by lepidochronology (modified from Guidetti et al., 2000).

Locality	Depth (m)	Leaf production		Leaf production		Growth rate		Rhizome production		Rhizome production		Total production	
		(g dw shoot <sup>-1</sup> yr <sup>-1</sup> )	N-fold	(g dw m <sup>-2</sup> yr <sup>-1</sup> )	N-fold	(cm shoot <sup>-1</sup> yr <sup>-1</sup> )	N-fold	(g dw shoot <sup>-1</sup> yr <sup>-1</sup> )	N-fold	(g dw m <sup>-2</sup> yr <sup>-1</sup> )	N-fold	(g dw m <sup>-2</sup> yr <sup>-1</sup> )	N-fold
Banyuls (France)	0.7–2	0.31–0.34	1.1	360.5–434.5	1.2	0.83–0.86	1.0	0.05–0.05	1.0	59.7–65.6	1.1	420.2–500.1	1.2
Port-Cros (France)	0.7–2	0.25–1.39	5.6	896.6–1177.5	1.3	0.67–0.69	1.0	0.05–0.06	1.2	38.3–42.9	1.1	934.9–1220.4	1.3
Urla-Iskele (Turkey)	0.7–2	1.0–1.09	1.1	510.0–1230.6	2.4	0.74–0.75	1.0	0.05–0.06	1.2	28.4–53.4	1.9	538.4–1284.0	2.4
	2–5	0.7–1.0	1.4	315.0–510.0	1.6	0.53–0.75	1.4	0.05–0.06	1.2	23.5–28.4	1.2	338.5–538.4	1.6
Alghero (Sardinia, It)	4–11	0.53–0.66	1.2	278.3–341.9	1.2	–	–	0.06–0.07	1.2	29.0–37.7	1.3	307.3–379.6	1.2
Medas Island (Spain)	5–6.5	–	–	781.1–923.4	1.2	–	–	–	–	–	–	–	–
Otranto (Italy)–S. Domino (Italy)	6.5–8	0.91–1.22	1.3	542.9–573.8	1.1	0.64–0.96	1.5	0.06–0.08	1.3	26.7–50.6	1.9	569.6–624.4	1.1
Sicily (It)	11–12	–	–	–	–	1.53–1.73	1.1	0.13–0.18	1.4	61.2–64.2	1.0	–	–
Stagnone di Marsala (Sicily, It)	1–1	0.6–1.2	2.2	112.1–417.4	3.7	0.4–1.3	3.0	0.03–0.15	5.0	5.5–51.9	9.4	117.6–469.3	4.0

\*The values of the Stagnone di Marsala were obtained in the present study. Also, the degree of difference in the mean values for each variable in each locality, expressed as how many times the maximum is greater than the minimum, is reported.

FOR INTERNAL USE ONLY

FOR INTERNAL USE ONLY

FOR INTERNAL USE ONLY

elab  
 PROVIDED FOR NON-COMMERCIAL RESEARCH USE  
 AND EDUCATION USE. NOT FOR REPRODUCTION,  
 DISTRIBUTION OR COMMERCIAL USE.



sources at the base of the food web, particularly seagrasses, can play a differential trophic role in the two sectors. Looking at Figure 5, one could argue that most fish in sector 5 had stable carbon and nitrogen ratios, thus suggesting an incorporation of enriched sources.

Considering a 2-trophic level enrichment of 2‰ and 7‰ for  $\delta^{13}\text{C}$  and  $\delta^{15}\text{N}$ , respectively (see Michener and Schell, 1994), if we subtract these values from  $\delta^{13}\text{C}$  and  $\delta^{15}\text{N}$  signatures of resident fish (on average  $210.6 \pm 1.2\text{‰}$  and  $11.7 \pm 1.2\text{‰}$  in sector 5 and  $212.0 \pm 0.9\text{‰}$  and  $11.5 \pm 2.7\text{‰}$  in sector 2), which are known to be secondary consumers on benthic prey (Scilipoti, 1998; Vizzini et al., 2002b), we calculate that the ultimate organic-matter sources for these consumers should have values of  $212.5\text{‰}$  and  $4.5\text{‰}$  in sector 5 and

$214\text{‰}$  and  $4.5\text{‰}$  in sector 2, respectively, for  $\delta^{13}\text{C}$  and  $\delta^{15}\text{N}$ . In sector 5, isotopic values of fish are consistent with an evident trophic role of seagrasses. Seagrasses, epiphytes, sedimentary and particulate organic matter (on average  $212\text{‰}$  and  $4\text{‰}$ ) seem to be the main sources at the base of the food web in sector 5, while the role of seagrasses seems to be negligible in sector 2. Since the seagrass living fraction and detritus showed similar isotopic compositions, the relative importance of the herbivore and detrital pathway in the central

sector is difficult to quantify. However, it is well documented that only about 10% of seagrass production is directly consumed by herbivores (Pergent et al., 1994), and as a consequence, we substantiate the importance of the detrital pathway in the study area. Accordingly, Vizzini et al. (2002b) have highlighted the trophic importance of the detrital fraction within the food web in the Stagnone di Marsala.

In the southern sector *P. oceanica*, despite its availability and high production, is a negligible trophic resource for consumers. This is consistent with the findings of the current literature. Accordingly, *Posidonia* appears to be a minor food source for consumers in the Gulf of Calvi (Corsica, FR; Dauby, 1989; Lepoint et al., 2000; Pinnegar and Polunin, 2000) and in the Island of Mallorca (Spain) (Jennings et al., 1997), while consumers fed mainly on plankton and algae. On the contrary, the results from the central sector of this study, which suggest a role of *Posidonia* for consumers, are difficult to compare with those obtained in studies from other Mediterranean areas. This can be related to the peculiarity of the study area. While the southern sector of the Stagnone is more affected by open-sea vivification, the central sector is characterized by specific environmental features such as low level of water exchange and depth, and it is difficult to compare with other Mediterranean *P. oceanica* meadows (Dauby, 1989; Jennings et al., 1997; Lepoint et al., 2000; Pinnegar and Polunin, 2000).

Our results suggest the idea that the exploitation and fate of organic matter above all in coastal systems are scarcely dependent on primary production (Cyr and Pace, 1993; Cebrián and Duarte, 1994; 1995), while being strictly dependent on environmental features. In the Stagnone, although *P. oceanica* coverage and primary production were lower in the central than southern region, the transfer of vascular material within the food web seems to be greater in the former. In our opinion, it can be implied that environmental features (i.e. water exchange) control the distribution and fate of organic matter. Within the Stagnone, the southern area is characterized by an elevated rate of seagrass primary production and is also affected by high water exchange and hydrodynamism (i.e. lateral drifting) (Sara' et al., 1999; 2001), which can determine the removal of locally produced organic matter (i.e. *P. oceanica* detritus) towards the central area (Balzano et al., 2000), where it undergoes resuspension and mineralization. Accordingly, the heterotrophic bacterial community in the sediments showed a higher density and biomass in the central than the southern sector (Mirto et al., submitted), making the detrital fraction more available to consumers. Thus, the low water exchange in the central region of the basin contributes to the accumulation and sinking of vascular matter, which is reintroduced to the food web after bacterial rearrangement.

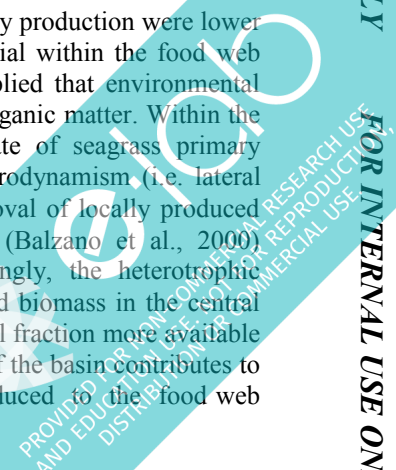

Although it is well known that coastal environments are characterized by high levels of ecological complexity, the results of this study substantiate the advantages of a multidisciplinary approach to gain a better understanding of complex and variable ecosystems.

## Acknowledgements

The Authors would like to thank Dr. F. Luzzu, Dr. A. Savona, Dr. A. Scannavino and Mr. D. Tuttolomondo for fieldwork; Dr. P. Cal`i, Dr. F. Cascino and Dr. G. Di Maida for laboratory analyses; Eng. Fabio Leto for help in hydrodynamic simulations; and Eleanor Cox for checking the English. This work was funded by Ministero dell'Istruzione, dell'Universita` e della Ricerca (MIUR, Italy; MIR research project).

## References

- Abbott, M. B. and Cunge, J. A. (1975). Two-dimensional modelling of tidal deltas and estuaries, in Mahmood, K. and Yevjevich, V. (eds.), *Unsteady flow in open channels*. Water Resources Publications, Fort Collins, CO, pp. 763 – 795.
- Adami, A., Dalla Villa, S. and Bernstein, A. (1997). Individuazione delle aree di possibile sviluppo di macroalghie nella laguna di Venezia: applicazione di un modello matematico idrodinamico. *L'Acqua*, rivista bimestrale della Associazione Idrotecnica Italiana, 3, 25 – 29.
- ASCE, Task Committee on Turbulence Models in Hydraulic Computations (1988). Turbulence modelling of surface water flow and transport. *Journal of Hydraulic Engineering*, 114, 970 – 1073.
- Balzano, A., Calvo, S., Ciralo, G. and La Loggia, G. (2000). Remote sensing as a tool to calibrate hydrodynamic model-transport numerical models, in Maione, U., Majone Lehto, B., and Monti, R. (eds.), *Proceedings of an International Conference 'New Trends in Water and Environmental Engineering for Safety and Life. Eco-compatible Solutions for Aquatic Environments'*, Capri (Italy), 3 – 7 July 2000. A. A. Balkema, Rotterdam, pp. 1 – 10.
- Balzano, A., Ciralo, G. and Nasello, C. (2002). Hydrodynamic finite element numerical simulations in a shallow coastal lagoon of Sicily. *Proceedings of Fifth International Conference on Hydroinformatics*, Cardiff (UK), 1, 358 – 364.
- Calvo, S., Ciralo, G. and La Loggia, G. (2003). Monitoring *Posidonia oceanica* meadows in a Mediterranean coastal lagoon (Stagnone, Italy), by means of neural network and ISODATA classifications methods. *International Journal of Remote Sensing*, 24, 1 – 14.
- Calvo, S. and Frada` Orestano, C. (1984). L'herbier a *Posidonia oceanica* des cotes siliciennes: les formations re`ci-fales du Stagnone, in Boudouresque, C. F., Meinesz, A., Fresi, E. and Gravez, V. (eds.), *International Workshop on Posidonia Beds. GIS Posidonie*, publ., Fr., Vol. 1, pp. 29 – 37.
- Calvo, S., La Loggia, G., Malthus, T. J., Savona, E. and Tomasello, A. (1996). Monitoring *Posidonia oceanica* meadows in the Mediterranean Sea by means of airborne remote sensing techniques, in *Proceedings of the Second International Airborne Remote Sensing Conference and Exhibition*, San Francisco, pp. 658 – 668.
- Calvo, S., Tomasello, A., Pirrotta, M., Cal`i, P., Cascino, F., Di Maida, G., Ciralo, G. and La Loggia, G. (2000). Temporal dynamic of *Posidonia oceanica* meadow in a coastal area affected by high climatic vulnerability (Stagnone lagoon – Western Sicily), in *Global Change IGBP-Censimento delle Ricerche Italiane-Workshop Nazionale CNR Rome*, pp. 258 – 259.
- Campolmi, M. (1998). Zooplankton community in the Stagnone di Marsala (West Med). PhD dissertation, University of Messina, Italy.
- Casulli, V. (1990). Semi-implicit finite difference methods for the two dimensional shallow water equations. *Journal of Computational Physics*, 86, 56 – 74.
- Casulli, V. and Cheng, R. T. (1992). On Lagrangian residual currents with application in South San Francisco Bay. *Water Resources Research*, 18, 1652 – 1662.
- Cebria`n, J. and Duarte, C. M. (1994). The dependence of herbivory on growth rate in natural plant communities. *Functional Ecology*, 8, 518 – 525.
- Cebria`n, J. and Duarte, C. M. (1995). Plant growth-rate dependence of detrital carbon storage in ecosystems. *Science*, 268, 1606 – 1608.
- Cebria`n, J. and Duarte, C. M. (2001). Detrital stocks and dynamics of the seagrass *Posidonia oceanica* (L.) Delile in the Spanish Mediterranean. *Aquatic Botany*, 70, 295 – 309.
- Cheng, R. T. and Casulli, V. (1992). Dispersion in tidally-averaged transport equation, in Prandle, D. (ed), *Dynamics and Exchanges in Estuaries and Coastal Zone*. American Geophysical Union, Washington D.C. pp. 409 – 428.
- Ciralo, G. (2000). Studio dell'interazione fra idrodinamismo e comparto biotico mediante tecniche integrate di modellistica numerica e telerilevamento: applicazione allo Stagnone di Marsala. PhD dissertation, University of Reggio Calabria.

- Clarke, K. R. and Warwick, R. M. (1994). Change in Marine Communities: an Approach to Statistical Analysis and Interpretation. Plymouth Marine Laboratory, Plymouth, UK.
- Cyr, H. and Pace, M. L. (1993). Magnitude and patterns of herbivory in aquatic and terrestrial ecosystems. *Nature*, 361, 148 – 150.
- Dauby, P. (1989). The stable carbon isotope ratios in benthic food webs of the Gulf of Calvi, Corsica. *Continental Shelf Research*, 9, 181 – 195.
- Deegan, L. A. and Garritt, R. H. (1997). Evidence for spatial variability in estuarine food webs. *Marine Ecology Progress Series*, 147, 31 – 47.
- Den Hartog, C. (1977). Structure, function, and classification in seagrass communities, in McRoy, C. P. and Helfferich, C. (eds.), *Seagrass ecosystems. A scientific perspective*. Dekker, New York, pp. 89 – 121.
- Duarte, C. M., Marbà, N., Agawin, N., Cebrian, J., Enriquez, S., Fortes, M. D., Gallegos, M. E., Merino, M., Olesen, B., Sand-Jensen, K., Uri, J. and Vermaat, J. (1994). Reconstruction of seagrass dynamics: age determinations and associated tools for the seagrass ecologist. *Marine Ecology Progress Series*, 107, 195 – 209.
- Ekebjærge, L. and Justesen, P. (1991). An explicit scheme for advection-diffusion modelling in two dimensions. *Computer Methods in Applied Mechanics and Engineering*, 88, 287 – 297.
- Flowers, T. J. (1985). Physiology of halophytes. *Plant and Soil*, 89, 41 – 56.
- Fonseca, M. S., Ziemann, J. C., Thayer, G. W. and Fisher, J. S. (1983). The role of current velocity in structuring eelgrass *Zostera marina* meadows. *Estuarine, Coastal and Shelf Science*, 17, 161 – 170.
- Fry, B. (1984). C/C ratio and the trophic importance of algae in Florida *Syringodium filiforme* seagrass meadows. *Marine Biology*, 79, 11 – 19.
- Fry, B. and Sherr, E. B. (1984). δC measurements as indicators of carbon flow in marine and freshwater ecosystems. *Contribution on Marine Science*, 27, 13 – 47.
- Giraud, G. (1979). Sur une méthode de mesure et de comptage des structures foliaires de *Posidonia oceanica* (Linnaeus) Delile. *Bulletin du Muséum d'Histoire Naturelle de Marseille*, 39, 33 – 39.
- Guidetti, P. (2000). Leaf primary production in *Posidonia oceanica*: two reconstructive aging techniques give similar results. *Aquatic Botany*, 68, 337 – 343.
- Guidetti, P., Buia, M. C. and Mazzella, L. (2000). The use of lepidochronology as a tool of analysis of dynamic features in the seagrass *Posidonia oceanica* of the Adriatic Sea. *Botanica Marina*, 43, 1–9.
- Hemminga, M. A. and Duarte, C. M. (2000). *Seagrass ecology*. Cambridge University Press, Cambridge.
- Jennings, S., Renones, O., Morales-Nin, B., Polunin, N. V. C., Moranta, J. and Coll, J. (1997). Spatial variation in the N and C stable isotope composition of plants, invertebrates and fishes on Mediterranean reefs: implications for the study of trophic pathways. *Marine Ecology Progress Series*, 146, 109 – 116.
- Kowalik, Z. and Murty, T. S. (1993). *Numerical modelling of oceans dynamics*. Advanced series on ocean engineering. World Scientific Publishing, Singapore.
- Leonard, B. P. (1979). A stable and accurate convective modeling procedure based on quadratic upstream interpolation. *Computer Methods in Applied Mechanics and Engineering*, 19, 59 – 98.
- Lepoint, G., Nyssen, F., Gobert, S., Dauby, P. and Bouqueneau, J. M. (2000). Relative impact of a seagrass bed and its adjacent epilithic algal community in consumer diets. *Marine Biology*, 136, 513 – 518.
- Maimone, G., Pugliesi, A., Campolmi, M., Sara, G. and Mazzola, A. (1998). Variazioni stagionali delle comunità fitoplanctoniche in relazione alle caratteristiche chimico-fisiche nello Stagnone di Marsala (Sicilia Occidentale). *Biologia Marina Mediterranea*, 5, 357 – 361.
- Mazzella, L., Buia, M. C., Gambi, M. C., Lorenti, M., Russo, G. F., Scipione, M. B. and Zupo, V. (1992). Plant – animal trophic relationships in the *Posidonia oceanica* ecosystem of the Mediterranean Sea: a review, in John, D. M., Hawkins, S. J. and Price, J. H. (eds.), *Plant – animal interactions in the marine benthos*. Clarendon Press, Oxford, Vol. 46, pp. 165 – 187.
- Mazzola, A. and Sara, G. (1995). Caratteristiche idrologiche di una laguna costiera mediterranea (Stagnone di Marsala-Sicilia Occ.): ipotesi di un modello qualitativo di circolazione lagunare. *Naturalista siciliano*, XIX, 229 – 277.
- Mazzola, A., Sara, G., Venezia, F., Caruso, M., Catalano, D. and Hauser, S. (1999). Origin and distribution of suspended organic matter as inferred from carbon isotope composition in a Mediterranean semi-enclosed marine system. *Chemistry and Ecology*, 16, 215 – 238.
- McRoy, C. P. and Helfferich, C. (1977). *Seagrass ecosystems*. Dekker, New York.
- Michener, R. H. and Schell, D. M. (1994). Stable isotope ratios as tracers in marine aquatic food webs, in Lajtha, K. and Michener, R. H. (eds.), *Stable Isotopes in Ecology*. Blackwell Scientific, Oxford, pp. 138 – 157.
- MIKE 21 (2000). *Handbook of the software: hydrodynamic and advection module*. DHI Water & Environment, Denmark.
- Minagawa, M. and Wada, E. (1984). Stepwise enrichment of N along food chains: further evidence and the relation between N and animal age. *Geochimica et Cosmochimica Acta*, 48, 1135 – 1140.
- Mirto, S., La Rosa, T., Mocciano, G., Costa, K., Sara, G. and Mazzola, A. (submitted) Meiofauna and benthic microbial biomass in a semi-enclosed Mediterranean marine system (Stagnone di Marsala, Italy). *Chemistry and Ecology*.
- Molenaar, H., Barthelemy, D., de Reffye, P., Meinesz, A. and Mialet, L. (2000). Modelling architecture and growth patterns of *Posidonia oceanica*. *Aquatic Botany*, 66, 85 – 99.
- Pergent, G. (1990). Lepidochronological analysis in the seagrass *Posidonia oceanica*: a standardised approach. *Aquatic Botany*, 37, 39 – 54.
- Pergent, G., Boudouresque, C. F. and Crouzet, A. (1983). Variations cycliques dans les écailles des rhizomes ortho-tropes de *Posidonia oceanica*. *Travaux Scientifiques du Parc national de Port-Cros*, 9, 107 – 148.
- Pergent, G. and Pergent, C. (1988). Actual state of the lepidochronological analysis in *Posidonia oceanica*. *Rapport. Commission. Internationale pour l'Exploration Scientifique de la Mer Méditerranée*, 31, 2.

- Pergent, G. and Pergent-Martini, C. (1991). Leaf renewal cycle of *Posidonia oceanica* in the bay of Lacco Ameno (Ischia, Italia) using lepidochronological method. *Posidonia Newsletter*, 4, 11 – 20.
- Pergent, G., Pergent-Martini, C. and Boudouresque, C. F. (1995). Utilisation de l'herbier a *Posidonia oceanica* comme indicateur biologique de la qualite' du milieu littoral en Meditterane'e: e'tat des connaissances. *Me'soge'e*, 54, 3 – 27.
- Pergent, G., Rico-Raimondino, V. and Pergent-Martini, C. (1997). Fate of primary production in *Posidonia oceanica* meadows of the Mediterranean. *Aquatic Botany*, 59, 307 – 321.
- Pergent, G., Romero, J., Pergent-Martini, C., Mateo, M. A. and Boudouresque, C. F. (1994). Primary production, stocks and fluxes in the Mediterranean seagrass *Posidonia oceanica*. *Marine Ecology Progress Series*, 106, 139 – 146.
- Peterson, B. J., Howarth, R. W. and Garritt, R. H. (1986). Sulfur and carbon isotopes as tracers of salt-marsh organic matter flow. *Ecology*, 67, 865 – 874.
- Pinnegar, J. K. and Polunin, N. V. C. (1999). Differential fractionation of  $\delta^{13}C$  and  $\delta^{15}N$  among fish tissues: implications for the study of trophic interactions. *Functional Ecology*, 13, 225 – 231.
- Pinnegar, J. K. and Polunin, N. V. C. (2000). Contributions of stable-isotope data to elucidating food webs of Mediterranean rocky littoral fishes. *Oecologia*, 122, 399 – 409.
- Pusceddu, A., Sara', G., Mazzola, A. and Fabiano, M. (1997). Relationship between suspended and sediment organic matter in a semi-enclosed marine system: the Stagnone di Marsala sound (western Sicily). *Water, Air and Soil Pollution*, 99, 343 – 352.
- Sand-Jensen, K. (1975). Biomass net production and growth dynamics in an eelgrass (*Zostera marina* L.) population in Vellerup Vig, Denmark. *Ophelia*, 14, 185 – 201.
- Sara', G., Catalano, D., Caruso, M. and Mazzola, A. (2001). L'influenza di alcune forzanti ambientali su origine e qualita' della materia organica sedimentaria in un ecosistema marino costiero (Stagnone di Marsala, Sicilia occidentale). *Naturalista siciliano*, XXV, 413 – 441.
- Sara', G., Leonardi, M. and Mazzola, A. (1999). Spatial and temporal changes of suspended matter in relation to wind and vegetation cover in a Mediterranean shallow coastal environment. *Chemistry and Ecology*, 16, 151 – 173.
- Savin, N. E. and White, K. J. (1977). The Durbin – Watson test for serial correlation with extreme sample sizes or many regressors. *Econometrica*, 45, 1989 – 1996.
- Scillipoti, D. (1998). Fish community in the Stagnone di Marsala: distribution and resource partitioning as a function of different habitat complexity degrees. PhD dissertation, University of Messina, Italy.
- Short, F. T. and Neckles, H. A. (1999). The effects of global climate change on seagrasses. *Aquatic Botany*, 63, 169 – 196.
- Sokal, R. and Rohlf, F. J. (1995). *Biometry*. W. H. Freeman, New York.
- Steever, E. Z., Warren, R. S. and Wiering, W. A. (1976). Tidal energy subsidy and standing crop production of *Spartina alterniflora*. *Estuarine, Coastal and Shelf Science*, 4, 473 – 478.
- Stelling, G. S., Wiersma, A. K. and Willemse, J. B. T. M. (1986). Practical aspects of accurate tidal computations. *Journal of Hydraulic Engineering*, 112, 802 – 817.
- Terrados, J. and Duarte, C. M. (2000). Experimental evidence of reduced particle resuspension within a seagrass (*Posidonia oceanica* L.) meadow. *Journal of Experimental Marine Biology and Ecology*, 243, 45 – 53.
- Underwood, A. J. (1997). *Experiment in Ecology*. Cambridge University Press, Cambridge.
- Vizzini, S., Sara', G., Michener, R. H. and Mazzola, A. (2002a). The trophic role of the macrophyte *Cymodocea nodosa* (Ucria) Asch. in a Mediterranean saltworks: evidence from carbon and nitrogen stable isotope ratios. *Bulletin of Marine Science*, 71, 1369 – 1378.
- Vizzini, S., Sara', G., Michener, R. H. and Mazzola, A. (2002b). The role and contribution of *Posidonia oceanica* (L.) Delile organic matter for secondary consumers as revealed by carbon and nitrogen stable isotope analysis. *Acta Oecologica*, 23, 277 – 285.
- Worcester, S. E. (1995). Effects of eelgrass beds on advection and turbulent mixing in low current and low shoot density environments. *Marine Ecology Progress Series*, 126, 223 – 232.

